

Seneca Kinship
Jean Mark Gawron
Semantics

<http://www-rohan.sdsu.edu/~gawron/semantics>

January 26, 2020

1 Seneca

This assignment is based on the analysis of the kinship system of the Seneca Iroquois Indians by Floyd Lounsbury 1964. This is already an old article, but, in fact, it continues a tradition of componential analysis of kinship terms that goes back at least to Kroeber (1909).

Your job is to come up with a componential analysis of your own based on the two data sets below. The data follow Lounsbury, who has made life a lot easier by arranging and dividing the terms into revealing patterns.

In thinking about appropriate features, make sure you think about the **contrasts** in the data. For example, the term glossed as “my elder brother” in the data below picks out a different set of relatives than the term glossed as “my cousin”. It is true that an “elder brother” has to be older than ego and a cousin does not, but there’s more to it than that, as Lounsbury’s data shows. Because the two terms pick out disjoint sets of relatives, *you must assign them different features*. They **contrast** in meaning.

Finally, be sure to go back and carefully test your features with some examples from Lounsbury’s lists, as well as with some examples you’ve generated on your own. It is possible that you will not be able to come up with an analysis that works. If so, I’d like you to present an analysis that partially works and explain what examples it does not correctly classify.

To get full credit you need only present an analysis; but if the analysis does not work, you must explain how it falls short. Full credit will not be given for an analysis claimed to be complete when it is not. It must also be the case that your features should be explicit enough so that it is clear how to apply them to every example, and there should be enough of them so they choose exactly one kinship term for any given example. **Finally you must define your features clearly.**

You may reuse features assumed in the mini-analysis of English kinship given above, and if you do so, you do not have define them. But if you reuse English features, be cautious. The concepts that play a role for English may or may not play a role for Seneca.

Seneca Kinship: data set 1

1.	haʔnih	my father	F, FB, FMSs, FFBS, FMBs, FFSs, FFFBss, etc.
2.	noʔyēh	my mother	M, MS, MMSd, MFBd, MMBd, MFSd, MMMSdd, etc.
3.	hakhnóʔsēh	my uncle	MB, MMSs, MFBs, MMBs, MFSs, MMMSds, etc.
4.	akeʔhak	my aunt	FS, FMSd, FFBd, FMBd, FFSd, FFFBsd, etc.
5.	hatsiʔ	my elder brother	B, MSs, FBs, MMSds, FFBss, MFBds, FMSss, MMBds, etc. (when older than ego)
6.	heʔkē:ʔ	my younger brother	(same, when younger than ego)
7.	ahtsiʔ	my elder sister	S, MSd, FBd, MMSdd, FFBsd, MFBdd, FMSsd, MMBdd, etc. (when older than ego)
8.	kheʔkē:ʔ	my younger sister	(same, when younger than ego)
9.	akyá:ʔse:ʔ	my cousin	MBs, FSs, MMSss, FFBds, MFBss, FMSds, MMBss, etc. also: MBd, FSd, MMSsd, FFBdd, MFBsd, FMSdd, MMBsd, etc.

Seneca Kinship: data set 2		
10.	he:hawak	my son (a) s, Bs, MSss, FBss, MBss, FSss, MMSdss, etc. for male ego; (b) s, Ss, MSds, FBds, MBds, FSds, MMSdds, etc. for female ego
11.	khe:hawak	my daughter (a) d, Bd, MSsd, FBsd, MBsd,FSsd, MMSdsd, etc. for male ego ; (b) d, Sd, MSdd, FBdd, MBdd, FSdd, MMSddd, etc. for female ego
12.	heyé:wō:tě?	my nephew Ss, MSds, FBds, MBds, FSds, MMSdds, etc. for male ego
13.	hehsó?neh	my nephew Bs, MSss, FBss, MBss, FSss, MMSdss, etc. for female ego
14.	kheyé:wō:tě?	my niece Sd, MSdd, FBdd, MBdd, FSdd, MMSddd, etc. for male ego
15.	khehsó?neh	my niece Bd, MSsd, FBsd, MBsd, FSsd, MMSdsd, etc. for female ego

2 Observations and suggestions

It may be useful to work on the first data set alone, and then revise and extend your solution to deal with the next set of cases, the younger generation words. However you do it, the solution you turn in should be a proposal considering all 15 cases. In other words you want to find one set of features that handles all 15 words as economically as possible.

1. SOME of the features that work for English basic kinship terms will also work for basic Seneca kinship terms, but not all. You will have to **define** some new features.
2. The *etc.* used in the definitions of many of the words cannot be eliminated. This is because the actual set of kinship types connected with a word like ha?nih (“father”) is infinite. Obviously ego and alter have to have some shared ancestor (this is a consanguineal relation), but that shared ancestor can be arbitrarily far back, so the chain of kinship

relations that connects ego to alter can be arbitrarily long. Your job is to find the generalization that distinguishes the haʔnih kinship types from others.

3. It will help to bear in mind the following fact: The extensions of the kinship terms are **disjoint**. For example, no relative can be both a haʔnih (“father”) and a hakhnóʔsēh (“uncle”).
4. Being older or younger than ego plays a role only where explicitly stated. Thus a akyá:ʔse:ʔ (“cousin”) is still a akyá:ʔse:ʔ, whether older or younger than ego.

References

- Jones, Doug. 2010. Human kinship, from conceptual structure to grammar. *Behavioral and Brain Sciences* 33(5):367.
- Kay, P. 1975. The generative analysis of kinship semantics: a reanalysis of the seneca data. *Foundations of language* 13(2):201–214.
- Kroeber, A.L. 1909. Classificatory systems of relationship. *The Journal of the Royal Anthropological Institute of Great Britain and Ireland* 39:77–84.
- Lounsbury, F.G. 1964. *The structural analysis of kinship semantics*. Mouton.

From Jones (2010)

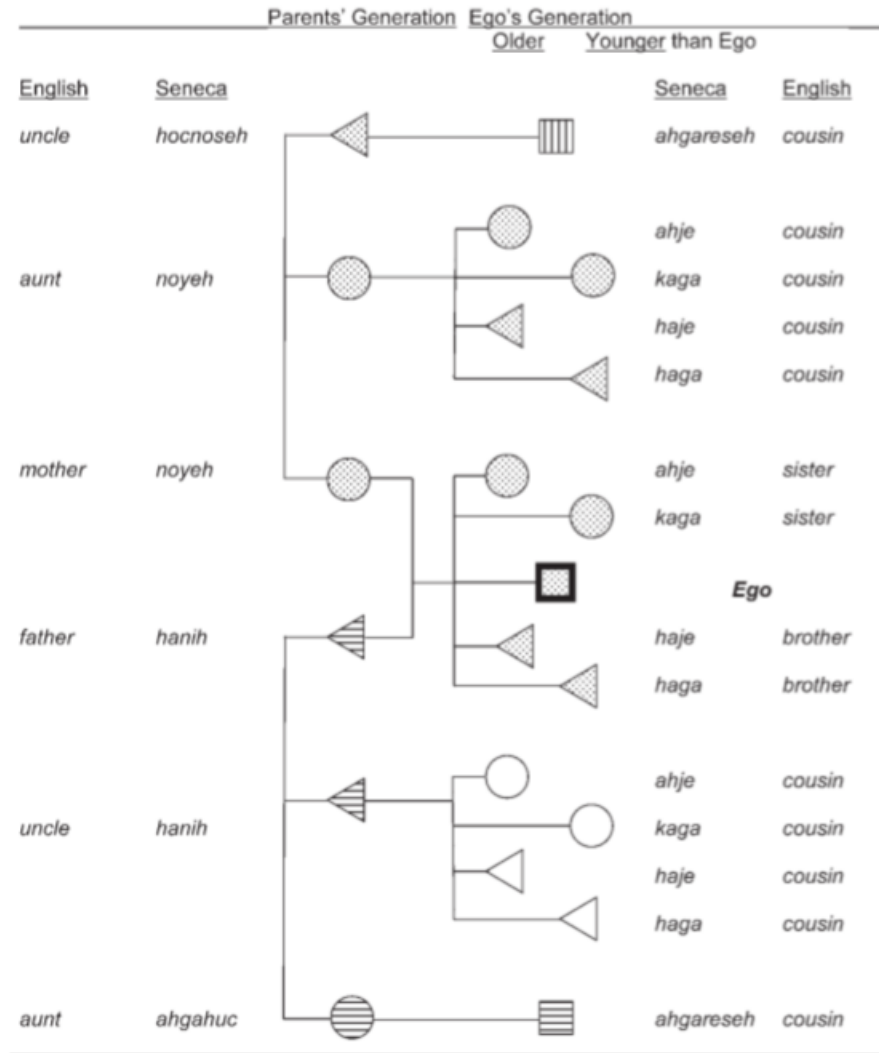

Figure 2. Some English and Seneca kin terms, in relation to **Ego** (center of chart). Circles are females, triangles males, squares either sex. Relative age (older or younger than Ego) is shown for siblings and some cousins. Shading indicates different lines of descent through females (matrilines).

Figure 1: Rough summary of the kinship facts for Gen -1 and Gen 0 relatives